



TECH-1000-1-96 HYDRAULIC DAVIT SYSTEM  
TECH-1000-2-96 HYDRAULIC DAVIT SYSTEM



TECH HYDRAULIC DAVIT SYSTEM

Nautical Structures' TECH-Davit System delivers the best in technology and value in small light-weight hydraulic davit systems. A davit system that is versatile and attractive in both style and price. The TECH-1000 Davit System is capable of lifting 1000 pounds, sufficient for small hard-bottomed inflatable boats and most personal watercraft. The basic **TECH-1000-1-96** davit incorporates a manually-positioned boom. The manual boom will articulate through its entire range of motion offering four positions of deployment. Nautical Structures' unique PBAS (**P**neumatic **B**oom **A**ssistance **S**ystem) feature counter-balances the weight of the boom for virtually effortless deployment. The **TECH-1000-2-96** incorporates a hydraulic boom that will articulate through its entire range of motion hydraulically while handling the full rated load capacity. Both davit models are fit with our acclaimed Hydraulic Linear Winch System, a silent-operating, non-fouling winch, and is operated by a remote controller on a eight-foot wanderlead, removable for security. Wireless remote control is available as an optional feature. The TECH-Davit System rotates smoothly by hand on Delrin bearings. Hydraulic power rotation may be selected as an optional feature. The TECH-Davit System is finished to our highest standards with a two-part *Aw/GRIP* urethane spray applied paint finish in a color of white to match your vessel.



**TECH-1000-1-96 HYDRAULIC DAVIT SYSTEM**  
**TECH-1000-2-96 HYDRAULIC DAVIT SYSTEM**

Davit is shown with the optional hydraulic rotating standpipe system.

**TECH-1000-3-96**

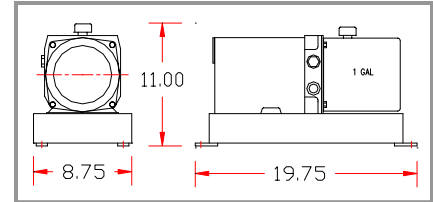

**1 Hp Hydraulic Power Unit**  
(Not in scale)

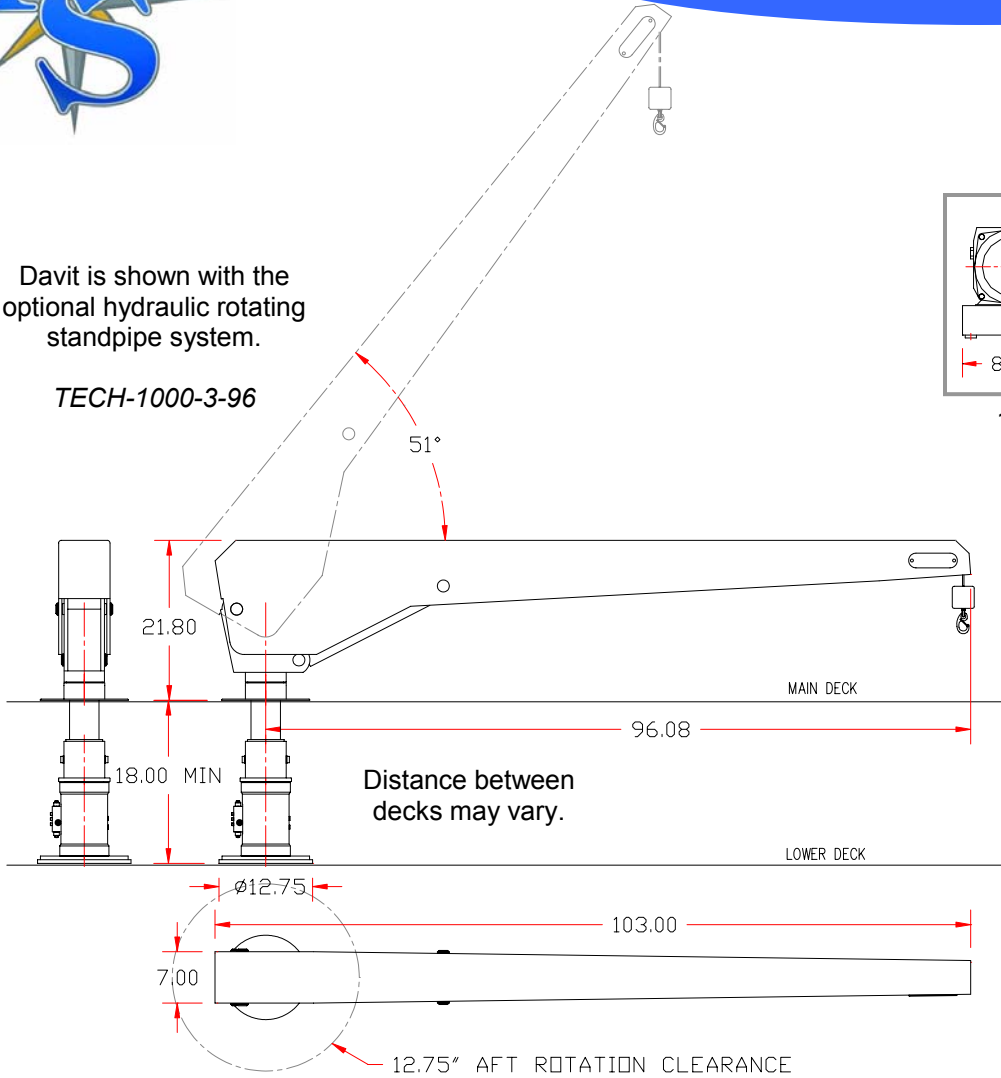

MECHANICAL SPECIFICATIONS		ELECTRICAL SPECIFICATIONS	
Reach (Maximum at 0°):	95" / 241 cm	12V DC Supply on a 100 Amp Breaker	24V DC Supply on a 80 Amp Breaker
Reach (Minimum at 51°):	53" / 135 cm	115/230V DC, 60Hz, 1-phase, 20a/15a service	
Aft Rotation Clearance:	12.7" / 32 cm	Remote control switch is wired to a 8' (2.5m) removable pendant.	Wireless remote control is available as an option.
Manual Rotation on Delrin Bearings:	360°	Use a minimum 4 gauge wire for supply power to a 80 amp breaker. For power runs in excess of 30' (9m) use a minimum 1-O wire. 12-3 boat wire for AC powered systems.	
Optional 180° or 360° Hydraulic Rotating Standpipe.		<b>RATED CAPACITY</b>	
Hydraulic Linear Winch System, 3/16" / 5mm Stainless steel wire rope, brass weight and stainless steel safety snap hook.			
Cable Pay-out:	18.0' / 5.48 m	TECH-1000-2-96 - 1000 POUNDS / 454 Kgs.	
Hydraulic Boom Luffing *The boom is capable of supporting full load capacity in all positions, from 0° (horizontal) to be capable of lifting the full 1000 pound/ 454 Kg rated load capacity.		12 Month Limited Warranty	
System weight, Davit System:	165 Lbs. / 75 Kgs		
System weight, Standpipe:	45 Lbs. / 20 Kgs		